

# Beam Test Results of the RADiCAL—A Radiation Hard Innovative EM Calorimeter

James Wetzel<sup>1</sup>, Dylan Blend, Paul Debbins, Max Hermann, Ohannes Kamer Koseyan, Gurkan Kamaran, Yasar Onel, *Member, IEEE*, Thomas Anderson, Nehal Chigurupati<sup>2</sup>, Brad Cox, Max Dubnowski, Alexander Ledovskoy, Carlos Perez-Lara, Thomas Barbera, Nilay Bostan, Kiva Ford, Colin Jessop, Randal Ruchti<sup>3</sup>, Daniel Ruggiero, Daniel Smith, Mark Vigneault, Yuyi Wan, Mitchell Wayne, Chen Hu<sup>4</sup>, Liyuan Zhang, and Ren-Yuan Zhu<sup>5</sup>, *Life Senior Member, IEEE*

**Abstract**—High-performance calorimetry conducted at future hadron colliders, such as the FCC-hh, poses a significant challenge for applying current detector technologies due to unprecedented beam luminosities and radiation fields. Solutions include developing scintillators that are capable of separating events at the sub-fifty picosecond level while also maintaining performance after extreme and constant neutron and ionizing radiation exposure. The radiation-hard innovative calorimeter (RADiCAL) is an approach that incorporates radiation tolerant materials in a sampling “shashlik”-style calorimeter configuration, using quartz capillaries filled with organic liquid or polymer-based wavelength shifters embedded in layers of tungsten plates and lutetium-yttrium oxyorthosilicate (LYSO) crystals. This novel design intends to address the priority research directions (PRD) for calorimetry listed in the DOE basic research needs (BRN) workshop for high energy physics (HEP) instrumentation. Here we report preliminary results from an experimental run at the Fermilab Test Beam Facility (FTBF) in June 2022. These tests demonstrate that the RADiCAL concept is capable of <50 ps timing resolution.

**Index Terms**—Calorimetry, fast-timing, radiation-hard, scintillator.

## I. INTRODUCTION

THE radiation-hard innovative calorimeter (RADiCAL) was initially conceived to target precision calorimetry for use in future hadron collider experiments [1]. The

Manuscript received 2 December 2022; revised 7 March 2023 and 7 April 2023; accepted 11 April 2023. Date of publication 19 April 2023; date of current version 18 July 2023. This work was supported in part by the United States Department of Energy (DOE) under Grant DE-SC0017810, in part by the NSF under Grant NSF-PHY-1914059, in part by the University of Notre Dame through the Resilience and Recovery Grant Program, and in part by the QuarkNet for High School (HS) Teacher and Student Support.

James Wetzel, Dylan Blend, Paul Debbins, Max Hermann, Ohannes Kamer Koseyan, Gurkan Kamaran, and Yasar Onel are with the Department of Physics and Astronomy, The University of Iowa, Iowa City, IA 52242 USA (e-mail: james-wetzel@uiowa.edu).

Thomas Anderson, Nehal Chigurupati, Brad Cox, Max Dubnowski, Alexander Ledovskoy, and Carlos Perez-Lara are with the Department of Physics, University of Virginia, Charlottesville, VA 22903 USA.

Thomas Barbera, Nilay Bostan, Kiva Ford, Colin Jessop, Randal Ruchti, Daniel Ruggiero, Daniel Smith, Mark Vigneault, Yuyi Wan, and Mitchell Wayne are with the Department of Physics and Astronomy, University of Notre Dame, Notre Dame, IN 46556 USA.

Chen Hu, Liyuan Zhang, and Ren-Yuan Zhu are with the Department of Physics, Caltech, Pasadena, CA 91125 USA.

Color versions of one or more figures in this article are available at <https://doi.org/10.1109/TNS.2023.3268590>.

Digital Object Identifier 10.1109/TNS.2023.3268590

0018-9499 © 2023 IEEE. Personal use is permitted, but republication/redistribution requires IEEE permission. See <https://www.ieee.org/publications/rights/index.html> for more information.

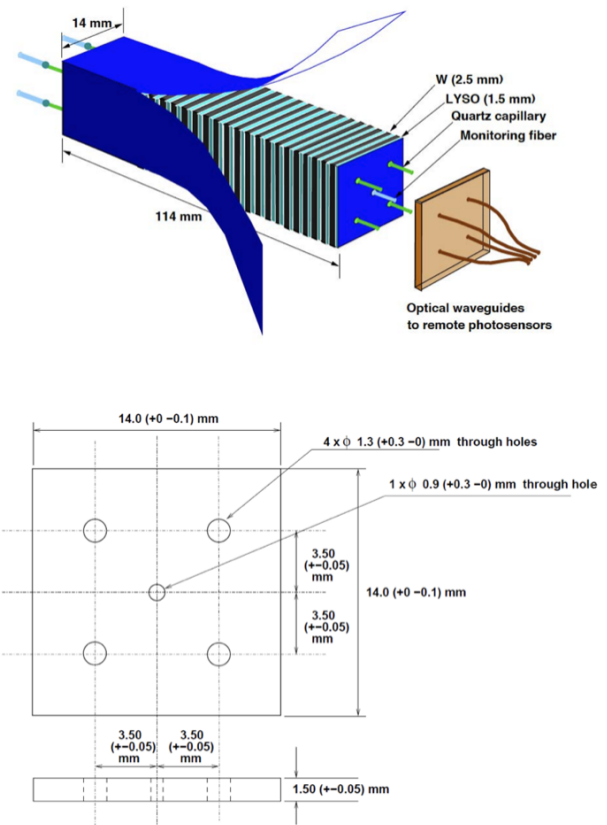

Fig. 1. Top: diagram of a RADiCAL module. Bottom: diagram of a RADiCAL tile.

requirements of such a collider include timing resolution under 50 ps and an EM energy resolution approaching  $\sigma_E/E = 10\%(E)^{1/2} \oplus 0.3/E \oplus 0.7\%$  [2].

To address these challenges, the RADiCAL concept envisions a shashlik style sampling calorimeter composed of many individual modules each 13 cm long and  $1.4 \times 1.4 \text{ cm}^2$  in cross section. Fig. 1 is a generic schematic of a single prototype RADiCAL module. Comprising such a module are 28 tiles of tungsten (2.5 mm thick) and 29 tiles of lutetium-yttrium oxyorthosilicate (LYSO) (1.5 mm thick). The radiation length of this structure is 4.7 mm and the Molière radius is 13.7 mm [3]. There are four 1.3 mm and one 0.9 mm diameter holes in each

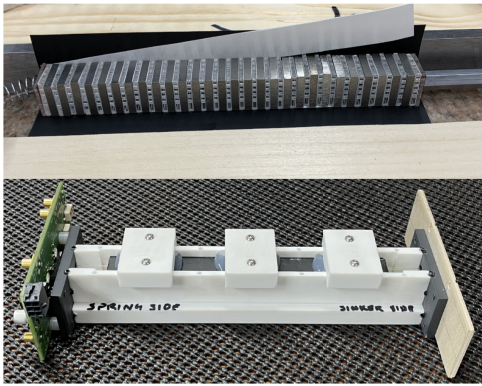

Fig. 2. Assembly of a RADiCAL module. Top: Shows the tiles being stacked. Bottom: Shows the delrin assembly.

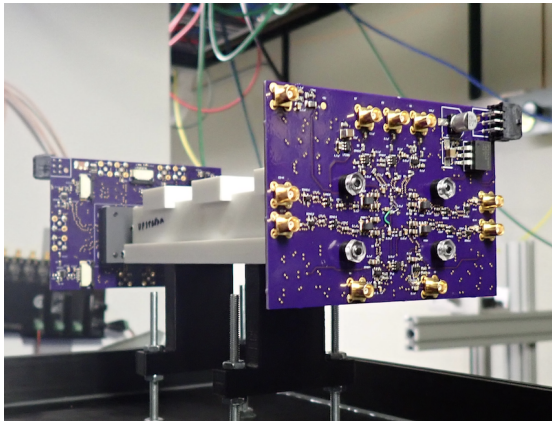

Fig. 3. RADiCAL module in the beam line at FTBF, June, 2022.

tile to allow for the insertion of quartz capillaries through the length of the module for optical readout, Fig. 1 (Bottom).

Monte Carlo simulations using GEANT4 [4], [5], [6] and previous test beam experiments of the RADiCAL concept using a  $4 \times 4$  array of RADiCAL modules demonstrated realistic expectations for achieving energy resolution performance goals [3], [7], and that testing an individual module is sufficient to investigate timing characteristics [3].

To further explore the potential timing characteristics, a single RADiCAL module was tested at the Fermilab Test Beam Facility (FTBF) [9] in June 2022 using a low-energy mixed pion-electron beam  $E = 28$  GeV, with preliminary results reported here.

## II. EXPERIMENTAL SETUP

A single RADiCAL module was prepared by stacking alternating tiles of LYSO and tungsten, separated by lasercut sheets of Tyvek, and placed in a milled delrin housing, shown in Fig. 2. Quartz capillaries were then inserted and readout cards attached. A RADiCAL module with both electronics cards attached is shown in the beam line in Fig. 3.

A RADiCAL capillary is a hollow quartz tube. Each capillary is 18 cm long, covering the active volume of the module and extending 2.5 cm from the module on either end, delivering light from the module to silicon photomultipliers (SiPMs) mounted on readout cards.

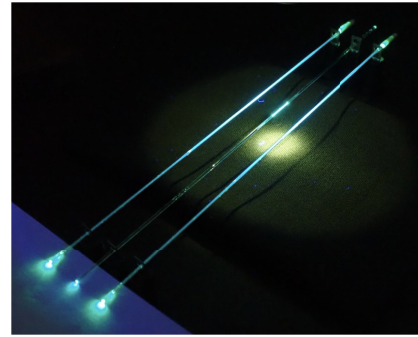

Fig. 4. Timing capillary between two energy capillaries.

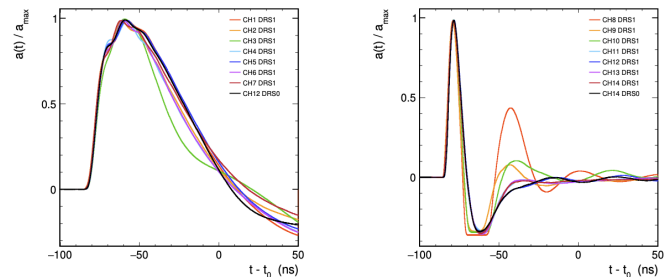

Fig. 5. Left: average normalized waveforms seen by the low gain. Right: high-gain channels during the June, 2022 run.

Two varieties have been used in tests of the RADiCAL concept. One is referred to as an energy capillary, and one is referred to as a timing capillary.

Energy capillaries are 1000  $\mu\text{m}$  in diameter, with a 400  $\mu\text{m}$  bore filled with the organic liquid EJ309 doped with proprietary wavelength shifter DSB1 [10]. One end of each liquid filled capillary has its core plugged and fused shut with a ruby quartz filament of 5 mm length. The ruby absorbs wave-shifted light traveling principally through the liquid core, preventing it from reaching the photosensors, while allowing light traveling preferentially through the core and quartz walls to be detected. This technique levels and makes uniform the longitudinal response of wave-shifted light collection [3].

Timing capillaries have an outer diameter of 1150  $\mu\text{m}$  and an inner bore with 950  $\mu\text{m}$  diameter and contain no liquid. In each end, the bore is plugged with a solid quartz rod and fused to create a single element. The two rods leave a gap at the location of shower max within the RADiCAL, determined as mentioned earlier from GEANT4 simulation [3], and that gap is filled with a 15 mm long polymer fiber containing DSB1 waveshifter of 900  $\mu\text{m}$  diameter. The light generated within a timing capillary therefore occurs from a region about shower max.

Fig. 4 reveals this localized light generation, comparing the UV illumination of a timing capillary situated between two energy capillaries in this figure.

These capillaries can be in any configuration within the module. The June 2022 configuration reported here used four timing capillaries. The center hole (envisioned for calibrating multiple modules) was unused in this test.

When particles enter the RADiCAL, they cause the LYSO tiles to scintillate. This light is absorbed by the DSB1 in the

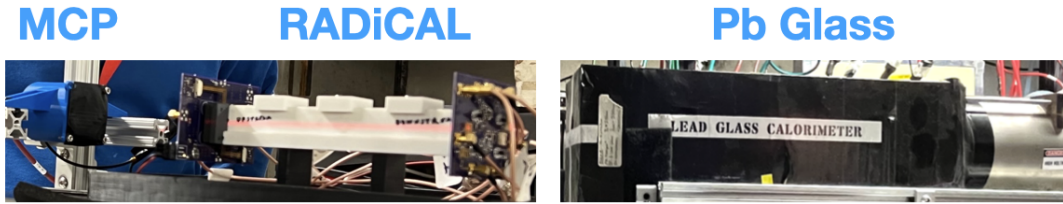

Fig. 6. MCP, the RADiCAL, and the LGC in alignment at the FTBF. The beam travels from the left to the right, hitting the MCP first.

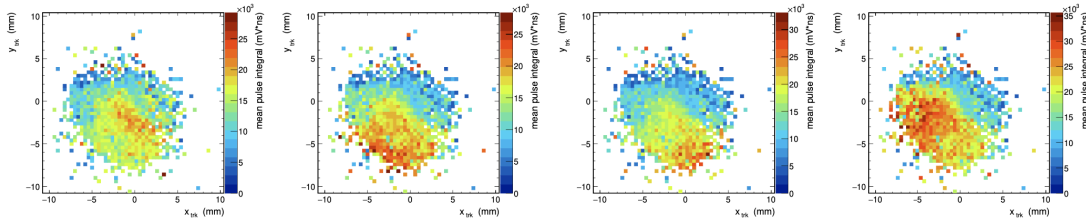

Fig. 7. Integrated low-gain signals in each capillary versus location of the particle in  $X$  and  $Y$ , demonstrating that larger signals are seen when particles hit closer to a capillary.

timing capillaries, waveshifted, then totally internally reflected to both ends where the capillaries contact the faces of the SiPMs.

Each SiPM had two readout circuits, one with a low-gain amplifier and one with a high-gain differential amplifier [8]. The low-gain amplifier was intended to give clear pulse shapes for energy measurement. The high-gain amplifier was intended to give fast sharp pulses for precise signal arrival time measurements. Fig. 5 shows average waveforms from the June 2022 run.

Fig. 6 shows the experiment's three important elements. The RADiCAL module was placed in the MT6 beam at the FTBF and aligned with a Hamamatsu R3809U-50 microchannel plate (MCP) to act as the trigger for data acquisition. This MCP has an expected time resolution  $\sigma \approx 10$  ps [11]. Behind these two modules was positioned a lead glass calorimeter (LGC) of dimensions  $15 \times 15 \times 50$  cm<sup>3</sup>. Its purpose was threefold: to record the energy of electromagnetic showers that might be only partially contained within the RADiCAL module; to measure the energy of beam particles that miss the RADiCAL altogether (including those particles which pass through the un-instrumented central hole of the RADiCAL); and to identify and discard hadrons and minimum ionizing particles (MIPs) that pass directly through the RADiCAL. This latter feature was important as the 28 GeV beam at the FTBF consists of electrons with a comparable admixture of pions and MIPs or MIPs [9].

Additionally, a silicon telescope [12] was positioned upstream of these elements in the beam line to provide tracking information for incoming beam particles and to measure their incident positions on the RADiCAL module.

Fig. 7 shows the measured energy versus projected track position from the silicon telescope for each capillary, showing a clear position dependence on how much light a capillary detects. This feature can be used to locate a particle (charged or uncharged) within a RADiCAL module based on the relative intensities of each capillary and hence with or without incident beam location information.

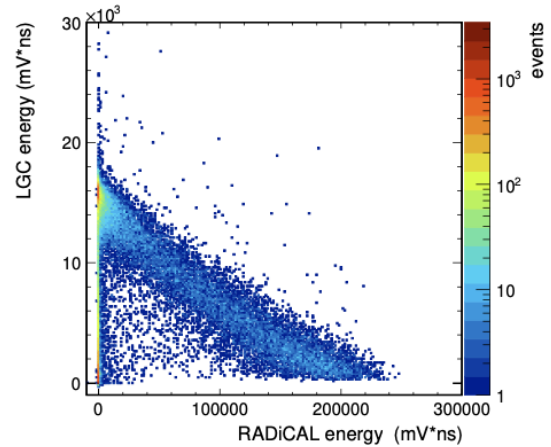

Fig. 8. Integrated signals (mV · ns) in the LGC versus integrated low-gain signals in the RADiCAL module for 28 GeV beam.

Data were acquired using two 16-channel CAEN DT5742 desktop digitizers. The signals from the RADiCAL and the LGC were fed into the digitizers, and the signal from the MCP was fed into the trigger input on both. A particle transiting the MCP creates a signal, triggering the DT5742 to start acquiring data. The MCP has a larger active area than the RADiCAL, so the triggering particle could deposit its energy in either the RADiCAL module or the LGC, or both. This allows the LGC to identify particles that the RADiCAL missed or only partially contained and allows us to select only events that were primarily contained by the RADiCAL.

The data recorded online were converted from a binary format to the ROOT format [13], the framework within which the data were subsequently analyzed for this report. Approximately, 70,000 events were taken with the 28 GeV beam in June, 2022.

### III. ANALYSIS

All waveforms were pedestal-subtracted with pedestal determined by averaging the first  $\approx 25$  ns of an event,

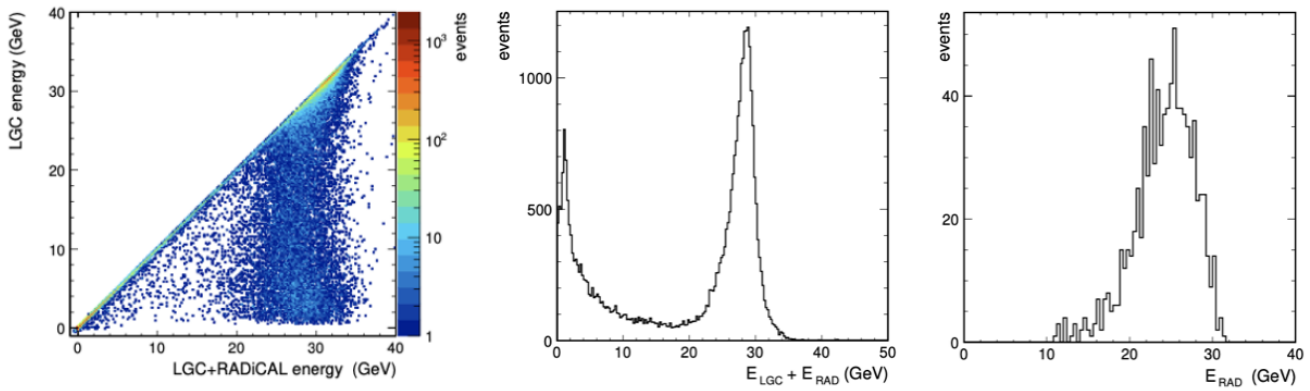

Fig. 9. Left: energy (GeV) in the LGC versus the sum of energy in the LGC and the RADiCAL module. Center: beam energy as reconstructed from the sum of LGC and RADiCAL signals with electron peak, MIP peak, and hadron tail present. Right: events reconstructed by the RADiCAL and the LGC with  $23 < E_{LGC} + E_{RAD} < 33$  GeV, event track within 3 mm of the RADiCAL center, and  $E_{RAD} > 10$  GeV.

or approximately 125 samples. Samples are taken every 0.2 ns. Low-gain signals were fit to determine the signal integral in units of  $\text{mV} \cdot \text{ns}$ .

To reconstruct the incident particle energy in GeV, the integrated signal in the LGC was plotted against the sum of all eight integrated low-gain signals from the RADiCAL module, in Fig. 8. The signals in  $\text{mV} \cdot \text{ns}$  for each event in each detector were then scaled to match the nominal 28 GeV beam energy. This is shown graphically in Fig. 9 (Center).

Events were then selected for timing analysis based on three main criteria: to select electron candidates from the mixed beam, the combined signal in the LGC and the RADiCAL was in the range 23 to 33 GeV. To discard tracks through the un-instrumented 1 mm diameter central hole of the RADiCAL, the signal in the RADiCAL module was required to be greater than 10 GeV. To minimize the position dependence of the timing measurement, the location of the incident track position determined by the silicon telescope fell within a circle of 6 mm diameter at the center of the RADiCAL module, as there were not enough statistics to correct for position dependence. We opted to select events from a small region in the center where we can assume the position dependence is negligible. The reconstructed energies of these selected events are shown in Fig. 9 (Right).

After this event selection, the time stamps were established for all eight high-gain readout channels as follows: a timestamp was set the moment a high-gain signal crossed a specific threshold. The level of this threshold was optimized for each channel to achieve the best time resolution [see Fig. 5 (Right)]. Then, event by event, the average of these eight time stamps was then compared with the corresponding reference time stamp provided by the trigger MCP. The resolution of this timing difference  $\sigma(t_{RAD} - t_{MCP})$  was then plotted as a function of the electron energy detected in the RADiCAL module, Fig. 10.

#### IV. RESULTS

As Fig. 10 indicates, the timing resolution of the RADiCAL module  $\sigma(t_{RAD} - t_{MCP})$  improves monotonically with increasing detected energy. This result is consistent with expectations from previous studies, which showed improved

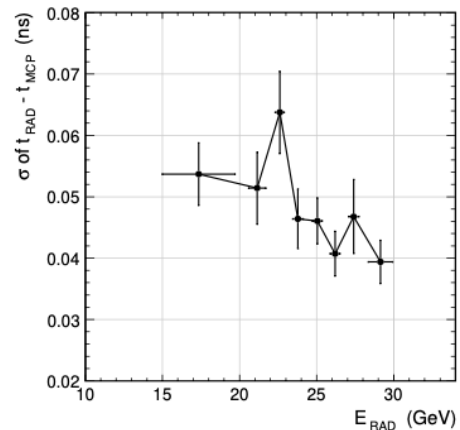

Fig. 10. Average timing resolution versus energy of the RADiCAL module.

timing resolution with increasing signal amplitude [3], [14]. Averaged over the fully detected electron energy range:  $E > 15$  GeV, the resolution of the timing difference is:  $\sigma(t_{RAD} - t_{MCP}) = 49.5 \text{ ps} \pm 5 \text{ ps}$ , demonstrating that the RADiCAL can achieve its time resolution objective.

In the portion of the data near the peak of the detected electron energy spectrum:  $23 < E_{RAD} < 30$  GeV, the resolution of the timing difference is:  $\sigma(t_{RAD} - t_{MCP}) = 43 \text{ ps} \pm 4.4 \text{ ps}$ . Given that the timing resolution of the MCP tube is  $\sigma(t_{MCP}) \approx 10 \text{ ps}$ , this yields a measured value of:  $\sigma(t_{RAD}) = 42 \text{ ps} \pm 4.3 \text{ ps}$  for a detected particle energy of  $E \approx 28$  GeV.

This preliminary result will be further refined with improved particle tracking while probing the timing performance as a function of detected electron energy.

#### V. CONCLUSION

A single module of a shashlik style sampling calorimeter (the RADiCAL) composed of alternating layers of LYSO and W, embedded with quartz capillaries filled with wavelength shifters were tested at Fermilab in June 2022. This test has demonstrated that the RADiCAL concept can achieve sub 50 ps timing resolution for a detected electron energy  $E = 28$  GeV. Combined with earlier measurements, the RADiCAL

has proven itself to be a fast, radiation hard calorimeter concept.

Future plans include measurements of the timing performance over an extended range of electron beam energies from  $25 < E < 200$  GeV.

#### ACKNOWLEDGMENT

The authors would like to thank the staff at the Fermilab Test Beam Facility (FTBF).

#### REFERENCES

- [1] B. Fleming. (2020). *Basic Research Needs for High Energy Physics Detector Research & Development*. [Online]. Available: [https://science.osti.gov/-/media/hep/pdf/Reports/2020/DOE\\_Basic\\_Research\\_Needs\\_Study\\_on\\_High\\_Energy\\_Physics.pdf](https://science.osti.gov/-/media/hep/pdf/Reports/2020/DOE_Basic_Research_Needs_Study_on_High_Energy_Physics.pdf)
- [2] M. Aleksa et al., "Calorimeters for the FCC-hh," CERN, Geneva, Switzerland, Tech. Rep. CERN-FCC-PHYS-2019-0003, Dec. 2019.
- [3] T. Anderson et al., "RADiCAL: Precision-timing, ultracompact, radiation-hard electromagnetic calorimetry," 2022, *arXiv:2203.12806*.
- [4] M. Asai, A. Dotti, M. Verderi, and D. H. Wright, "Recent developments in Geant4," *Ann. Nucl. Energy*, vol. 82, pp. 19–28, Aug. 2015.
- [5] J. Allison et al., "Geant4 developments and applications," *IEEE Trans. Nucl. Sci.*, vol. 53, no. 1, pp. 270–278, Feb. 2006.
- [6] S. Agostinelli et al., "Geant4—A simulation toolkit," *Nucl. Instrum. Methods Phys. Res. Sect. A, Accel., Spectrometers, Detectors Associated Equip.*, vol. 506, no. 3, pp. 250–303, 2003.
- [7] T. Anderson et al., "RADiCAL—Precision timing, ultracompact, radiation-hard electromagnetic calorimetry," *Instruments*, vol. 6, no. 3, p. 27, Aug. 2022.
- [8] J. W. Cates, S. Gundacker, E. Auffray, P. Lecoq, and C. S. Levin, "Improved single photon time resolution for analog SiPMs with front end readout that reduces influence of electronic noise," *Phys. Med. Biol.*, vol. 63, no. 18, Sep. 2018, Art. no. 185022.
- [9] *Fermilab Test Beam Facility*. Accessed: Apr. 2023. [Online]. Available: <https://ftbf.fnal.gov>
- [10] Scintillators Eljen Technologies, Sweetwater, TX, USA. [Online]. Available: <https://eljentechnology.com/>
- [11] J. Bortfeldt et al., "Timing performance of a micro-channel-plate photomultiplier tube," *Nucl. Instrum. Methods Phys. Res. Sect. A, Accel., Spectrometers, Detectors Associated Equip.*, vol. 960, Apr. 2020, Art. no. 163592.
- [12] *Pixel Telescope Description*. Accessed: Apr. 2023. [Online]. Available: <https://ftbf.fnal.gov/si-pixel-telescope/>
- [13] R. Brun and F. Rademakers, "ROOT—An object oriented data analysis framework," in *Nuclear Instruments and Methods in Physics Research Section A: Accelerators, Spectrometers, Detectors and Associated Equipment*. Lausanne, Switzerland: 1997, pp. 81–86. [Online]. Available: <https://www.sciencedirect.com/science/article/abs/pii/S016890029700048X>
- [14] D. Anderson et al., "On timing properties of LYSO-based calorimeters," *Nucl. Instrum. Methods Phys. Res. A, Accel. Spectrom. Detect. Assoc. Equip.*, vol. 794, pp. 7–14, Sep. 2015.