

Studies of Wavelength-Shifting Liquid Filled Quartz Capillaries for Use in a Proposed CMS Calorimeter

B. Baumbaugh, T. Adams, M. Arenton, A. Askew, R. Becker, B. Bilki, A. Bornheim, B. Cox, P. Debbins, N. Dev, G. Dissertori, B. Dolezal, K. Ford, S. Goadhouse, R. Hirosky, A. Heering, C. Jessop, H. Li, P. Link, W. Lustermann, M. Marinelli, M. McKenna, P. Meridani, F. Micheli, C. Mohs, Y. Musenko, F. Nessi-Tedaldi, C. Neu, H. Newman, Y. Onel, R. Ruchti, N. Siwiets, M. Spiropulu, T. Tabarelli-de Fatis, J. Taylor, M. Vigneault, M. Wayne, F. Yang, L. Zhang, R-Y Zhu,

Abstract— Studies have been done and continue on the design and construction of a Shashlik detector using Radiation hard

quartz capillaries filled with wavelength shifting liquid to collect the scintillation light from LYSO crystals for use as a calorimeter in the Phase II CMS upgrade at CERN. The work presented here focuses on the studies of the capillaries and liquids that would best suit the purpose of the detector. Comparisons are made of various liquids, concentrations, and capillary construction techniques will be discussed.

Manuscript received Nov. 23 2015. This work was supported in part by the U.S. National Science Foundation under Grant NSF-PHY-1312842. We would like to thank the NSF for its support.

T. Adams is with Florida State University, Department of Physics, 7, Chieftan Way, Tallahassee, FL 32306

M. Arenton is with University of Virginia, Department of Physics, 382 McCormick Rd, Charlottesville, VA 22904

A. Askew is with Florida State University, Department of Physics, 7, Chieftan Way, Tallahassee, FL 32306

B. Baumbaugh is with the University of Notre dame, Notre Dame, IN 46556 (telephone 574-631-9384, email bbaumbau@nd.edu)

R. Becker is with ETH Zurich, HPF G 9.3, Otto-Stern-Weg1, 8093 Zurich, Switzerland

B. Bilki is with the University of Iowa, Dept of Physics and Astronomy, Iowa City, IA 52242

A. Bornheim is with Caltech Department of Physics, 1200 E. California Blvd, Pasadena, CA 91125

B. Cox is with University of Virginia, Department of Physics, 382 McCormick Rd, Charlottesville, VA 22904

P. Debbins is with the University of Iowa, Dept of Physics and Astronomy, Iowa City, IA 52242

N. Dev is with the University of Notre Dame, Notre Dame, IN 46556

G. Dissertori is with ETH Zurich, HPF G 9.3, Otto-Stern-Weg1, 8093 Zurich, Switzerland

B. Dolezal is with the University of Notre Dame, Notre Dame, IN 46556 (telephone 574-631-9384)

K. Ford is with the University of Notre Dame, Notre Dame, IN 46556 (telephone 574-631-6443)

S. Goadhouse is with University of Virginia, Department of Physics, 382 McCormick Rd, Charlottesville, VA 22904

R. Hirosky is with University of Virginia, Department of Physics, 382 McCormick Rd, Charlottesville, VA 22904

A. Heering is with the University of Notre Dame, Notre Dame, IN 46556

C. Jessop is with the University of Notre Dame, Notre Dame, IN 46556

Al Ledovskoy is with University of Virginia, Department of Physics, 382 McCormick Rd, Charlottesville, VA 22904

H. Li is with University of Virginia, Department of Physics, 382 McCormick Rd, Charlottesville, VA 22904

P. Link is with the University of Notre Dame, Notre Dame, IN 46556

W. Lustermann is with ETH Zurich, HPF G 9.3, Otto-Stern-Weg1, 8093 Zurich, Switzerland

M. Marinelli is with the University of Notre Dame, Notre Dame, IN 46556

M. McKenna is with the University of Notre dame, Notre Dame, IN 46556

P. Meridani is with INFN Roma 1, Dipartimento de Fisica, Universita degli Studi di Roma "La Sapienza", P. le Aldo Moro 2, 00185 Roma, Italy

F. Micheli is with ETH Zurich, HPF G 9.3, Otto-Stern-Weg1, 8093 Zurich, Switzerland

C. Mohs is with the University of Notre Dame, Notre Dame, IN 46556

Y. Musenko is with the University of Notre Dame, Notre Dame, IN 46556

F. Nessi-Tedaldi is with ETH Zurich, HPF G 9.3, Otto-Stern-Weg1, 8093 Zurich, Switzerland

I. INTRODUCTION

THE work presented here will detail studies done using liquid filled radiation hard quartz capillaries for wavelength shifting in Shashlik detector for high luminosity experiments such as the CMS experiment at CERN. Here we will discuss the development, production and testing of sealed liquid filled capillaries. We will briefly discuss the initial attempts made using refillable capillaries and the associated issue with that method, as well as the testing and evaluation of different dyes used in the liquids and varying concentrations of these dyes to maximize efficiency as well as keeping the response linear along the length of the capillary.

C. Neu is with University of Virginia, Department of Physics, 382 McCormick Rd, Charlottesville, VA 22904

H. Newman is with Caltech Department of Physics, 1200 E. California Blvd, Pasadena, CA 91125

Y. Onel is with the University of Iowa, Dept of Physics and Astronomy, Iowa City, IA 52242

R. Ruchti is with the University of Notre Dame, Notre Dame, IN 46556 (telephone 574-631-7143, email rrruchti@nd.edu)

N. Siwiets is with the University of Notre Dame, Notre Dame, IN 46556

M. Spiropulu is with Caltech Department of Physics, 1200 E. California Blvd, Pasadena, CA 91125

T. Tabarelli-de is with INFN Milano Bicocca, Via Fratelli Cervi 201, Segrate, MI, Italy

J. Taylor is with the University of Notre Dame, Notre Dame, IN 46556

M. Vigneault is with the University of Notre Dame, Notre Dame, IN 46556 (telephone 574-631-9384)

M. Wayne is with the University of Notre Dame, Notre Dame, IN 46556

F. Yang is with Caltech Department of Physics, 1200 E. California Blvd, Pasadena, CA 91125

L. Zhang is with Caltech Department of Physics, 1200 E. California Blvd, Pasadena, CA 91125

R-Y Zhu is with Caltech Department of Physics, 1200 E. California Blvd, Pasadena, CA 91125

II. THE SHASHLIK TEST DETECTOR

The purpose of this work is to develop an EM calorimeter for use in experiments such as CMS or other high luminosity environments with an expected ionizing radiation of 150 Mrad, up to 3×10^{14} protons/cm² and up to 5×10^{15} n/cm², and with significant event pileup (140-200/crossing).

The design uses dense materials to minimize modular transverse size (small Moliere Radius) and provide significant radiation lengths ($\sim 25X_0$) in reduced depths. It exploits radiation hard materials and keeps optical paths as short as possible.

The current test Shashlik module design consist of 29 cerium doped LYSO plates and 28 Tungsten (W) plates. The cerium doped LYSO (referred from now on as LYSO) plates are 1.5mm thick and 14mm x 14mm on a side. The tungsten plates are 2.5mm thick and 14mm x 14mm on a side. Each plate has 5 holes drilled in it on a 7mm x 7mm pattern with one hole in the center. Each hole is 1.6mm diameter on the test cell to accommodate a 1.2mm diameter plastic Y11 fiber (Kuraray double clad fiber). The center hole is used for a 0.9mm diameter calibration fiber from a laser test system.

The Tungsten plates provide high material density and short radiation length. The LYSO plates provide the active portion of the detector. As particles pass through the LYSO scintillation light is collected in them at ~ 425 nm. This light propagates within the crystal plate until some fraction is collected as it passes into the liquid filled wave-shifting capillaries where it is shifted to ~ 500 nm and is then transmitted to the readout end in the quartz material.

See Fig. 1 which shows the design of the current modules.

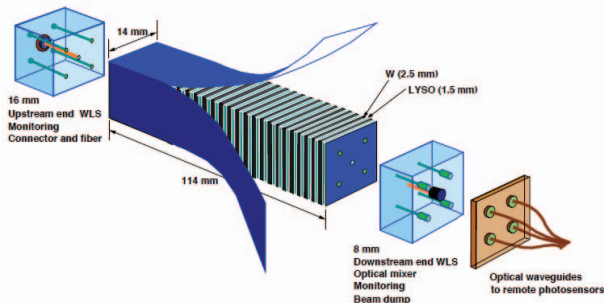

Fig1. Schematic of current test module.

The plates are assembled in a stack consisting of alternating layers of LYSO and tungsten. Each layer also has a 0.001 inch thick aluminum foil layer to reflect light back into the LYSO.

In the current test system, 16 modules were assembled and put together as a 4 x 4 super module array (see Fig.2). For the array 64 WLS fibers were inserted and glued into connectors at each end which were then polished in the P3 machine at Fermi National Accelerator Lab. Then cables were made to take each fiber's signal to an individual Silicon Photo-Multipliers (SiPMs). In this test both ends were read out for a total of 128 channels.

In this test Y11 plastic wave-shifting fibers of 1.2mm were used. To test the detector characteristics. These fibers are not radiation hard, and would not be used in any final design. Liquid filled radiation hard capillaries will replace these and will be discussed later. Initial tests were conducted using a system that would allow refilling the capillaries. This design had issues with sealing the capillaries so we moved to a single sealed capillary that can be removed and replaced if needed.

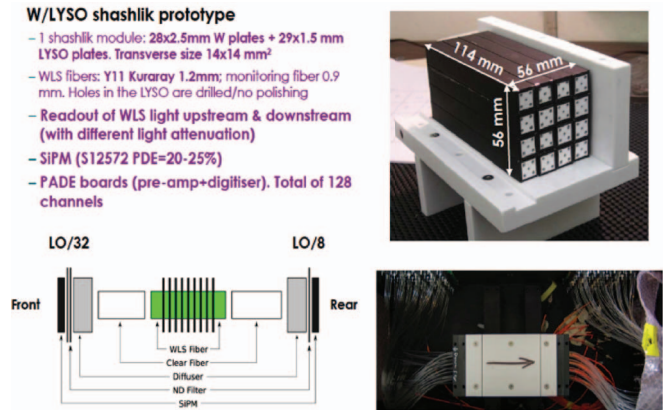

Fig. 2 Picture of current test setup.

Fig. 3 shows the schematic of the light based EM calorimeter considered for the CMS phase 2 Endcap region.

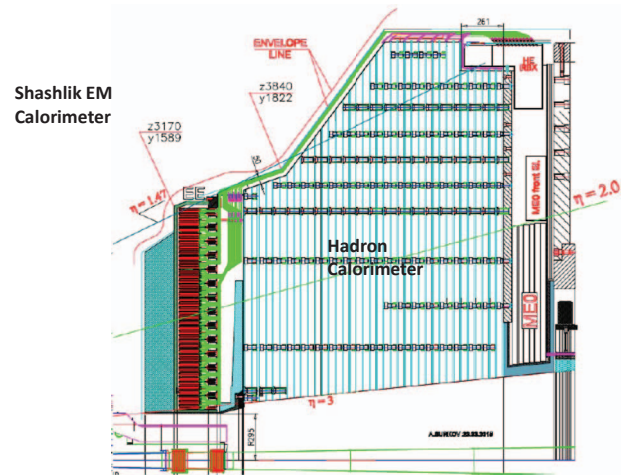

Figure 3. Schematic cut away view of location of Shashlik EM calorimeter.

III. TEST RESULTS FROM SHASHLIK TEST SYSTEM

The test system was tested in the H4 test beam at CERN in 2014. Energy resolution was measured with the electron beam and the results can be seen in Fig. 4.

Fig. 5 shows the energy resolution estimated from GEANT4. The graph shows resolution based on various sources of estimated error. Fig. 6 shows energy resolution as a function of pseudo rapidity (η) after exposure to an

integrated luminosity of 3000fb-1. Notably there is little change below ets ~ 2.5

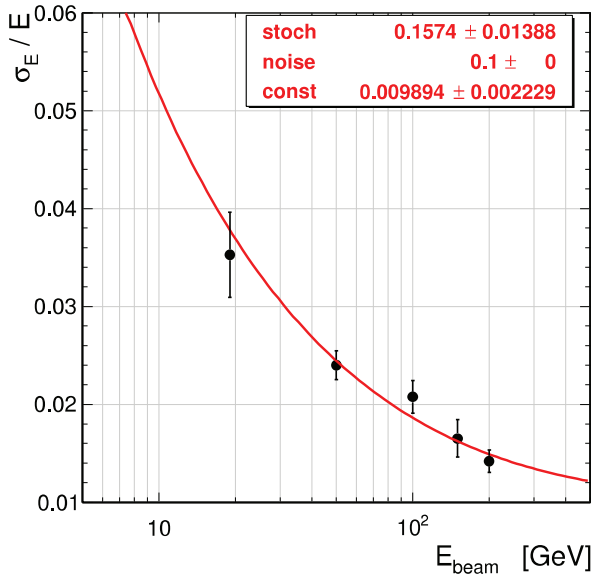

Fig.4 Energy resolution of the test Shashlik detector.

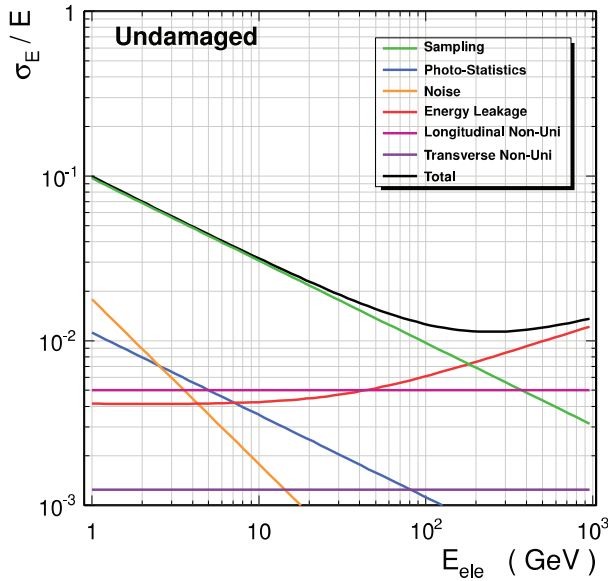
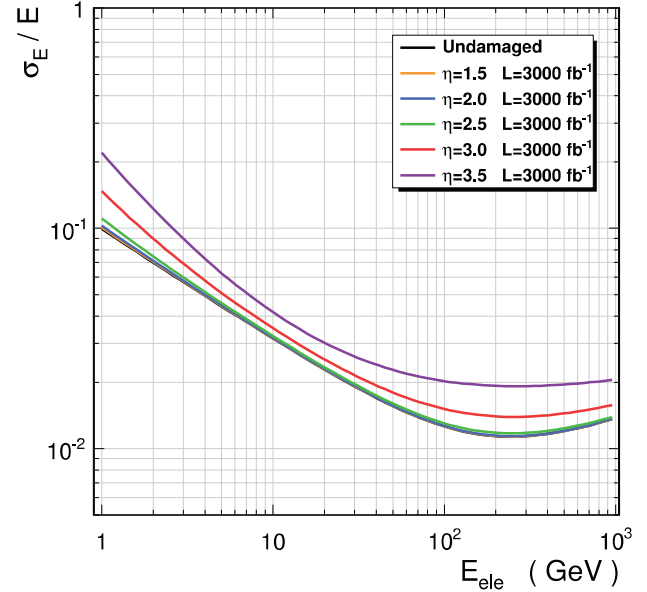

Fig. 5. GEANT4 energy resolution estimates based on error sources.

IV. REPLACEMENT OF PLASTIC FIBERS USING LIQUID WAVE-SHIFTER FILLED RADIATION HARD QUARTZ CAPILLARIES.

In order to make the detector more radiation hard we developed we developed thick walled liquid filled quartz capillaries that are relatively radiation tolerant. The capillaries are made currently by the glass shop in the Radiation Laboratory at Notre Dame. We start with a 250mm long high OH⁻ quartz capillary tube, 1mm OD x 0.4mm ID made by

PolyMicro of Phoenix, AZ. These blank capillaries are then sealed using a ruby quartz plug made by Technical Glass Products of Painesville Twp., OH. The glass shop at Notre Dame draws the ruby quartz into a small diameter fiber and uses this small rod to seal the end. This end is then cut to length and polished. The ruby quartz is not radiation hard and



as it is

Fig. 6. GEANT4 energy estimation after radiation damage.

exposed to radiation it darkens, it also blocks the core light due to its red color which helps eliminate the $\sim 500\text{nm}$ light only from the core of the capillary.

Next a $\sim 2\text{mm}$ diameter bubble is blown into the capillary to allow a void that will accommodate any expansion or contraction of the liquid as the temperature changes. The capillary is then evacuated and sealed. The capillary is placed in a special fixture that allows the just sealed end to be placed in liquid after a small score is put on the capillary. While under liquid the sealed end is broken at the score and the liquid is drawn into the capillary. The end is now sealed at the break after sufficient liquid is removed to create the void in the bubble used to accommodate expansion/contraction. The end now has a short (0.5 inch) piece of heat shrink tubing placed over it and shrunk in place to protect the fragile sealed end. This also allows us to mark the end to identify each capillary individually.

This process usually leaves a small void at the ruby quartz (readout) end of the capillary that has to be removed using a custom centrifuge, as the void cause an inconsistent optical characteristic at the read out end. Once the capillary is centrifuged, a diffuse reflective paint is then applied to the last 5mm before the bubble, and the capillary is tested to characterize it. It then can be installed into the test system, or we can irradiate it and continue testing it to see how it performs.

Fig. 7 shows a schematic of the capillary after manufacture. In this figure the bubble is also coated with TiO_2 , but we found that after multiple test this had little effect. It was eliminated to allow inspection of the void created on the liquid at the bubble to verify it was there and would allow liquid expansion. Fig. 8 shows a completed capillary and close up images of the bubble and diffuse reflector.

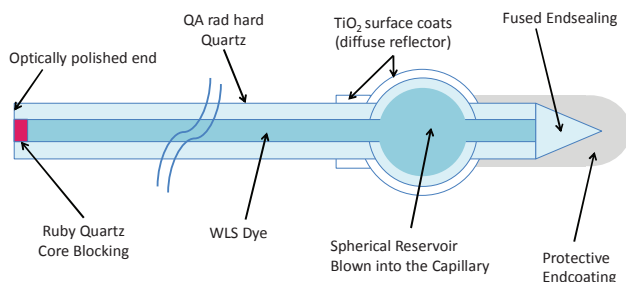
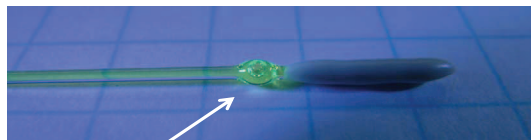
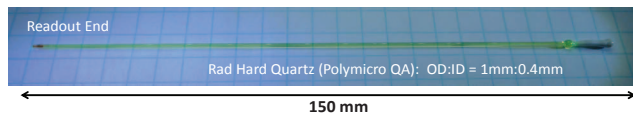
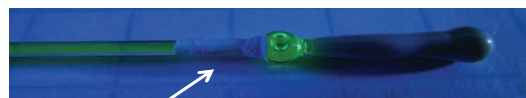

Fig. 7. Schematic of a finished capillary.



Thermal Expansion Reservoir



Diffusive Reflector (DR) Surface Coating just before the Reservoir

Fig. 8. Capillary images.

Note that in the images above the sealed end is protected by an epoxy coating. This has been replaced on capillaries going into the test system at CERN with a shrink tube protecting the fragile seal at the end.

V. SELECTION OF LIQUID AND CORE BLOCKING

Selection of the best liquid and capillary design required the making of over 100 capillaries. We tested the liquids (J2, and DSB1), the concentrations from X6 down to X0.125, the use of core blocking, and the use of a diffusive reflector to make the capillaries with the best light performance, radiation resistance and flattest response along the length of the capillary.

A. Liquid selection

For these test we used two main liquids. Both made by Eljen Technologies of Sweetwater, Texas. These liquids were solutions made using EJ309 liquid scintillator quenched to eliminate scintillation in the EJ309. We made capillaries with J2 and DSB1, but focused on DSB1 as our choice due to its short fluorescence decay time which is 2.5 times faster than J2 (J2 is similar to Y11 in all characteristics).

The solution of DSB1 was referred to as 11A the A refers to the type of quenching agent used. The normal concentration provided by Eljen is what we referred to as X1. We decided to try various concentration to test the effects of light output as well as linearity. Because as light traverses the capillary it can travel through the liquid filled core, this can lead to re-absorption and re-emission, and losses. This is why we tried the various concentrations. Studies quickly showed that the higher concentration could yield more light to a point, but the linearity suffered. Lower concentrations seemed to yield better results. After initial test we settled on X0.5 for our beam test and studied that concentration more closely.

B. Core Blocking

It is desirable to block light from the liquid core and to collect WLS light via the quartz cladding which is radiation hard. This is done to avoid the optical attenuation due to direct detection of the core light, due to self-absorption in the WLS medium. The light from the core near the readout end will be higher than from the far end unless the core is blocked, hence the core blocking. We are most interested in the light propagates primarily through the quartz wall of the capillary. Technical Glass Products of Painesville Twp., OH makes a quartz material called ruby quartz that has the optical characteristics we needed by blocking the $\sim 500\text{nm}$ core light. The material needed to be a quartz material in order to match the thermal characteristics of the capillary. This ruby quartz is drawn down to the proper size to “plug” the readout end and is then sealed into the capillary by the Notre Dame Glass shop. The ruby quartz is not radiation hard, and its light blocking improves as the dose increases, which works in our favor.

VI. CAPILLARY TESTING

We use three tests to evaluate the capillaries. Two test the current of a photodiode that looks at the readout end and one gives us a digitized visual image of the readout end.

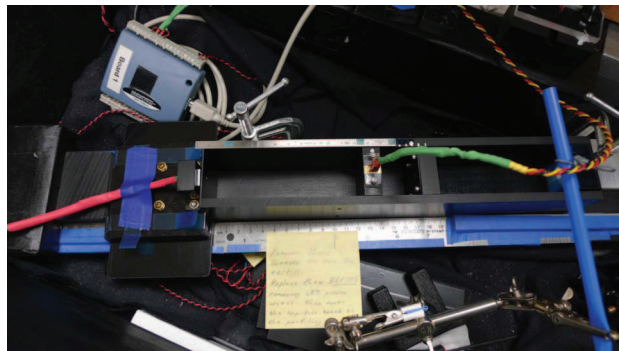

Fig. 9 Basic test bed for LED tests.

A. LED Measurements

The primary test we do is to place the capillary in a test jig (see Fig. 9) that uses a 425 nm LED to excite the liquid directly at various points along the capillary.

As a check on the direct LED test we use a 355 nm LED to excite a LYSO crystal. The capillary passes through this crystal just as it would in the Shashlik module. This 355 nm LED excites the LYSO which in turn excites the liquid. Our test have shown good agreement between these two methods.

B. CCD image tests

This test uses a CCD imager with a coherent fiber optic input window. This allows us to see directly and spatially how well the core blocking is working and to the light emerging from the capillary. Fig. shows the end of a capillary and the core blocking. This is a regular camera and photograph not from the CCD imager

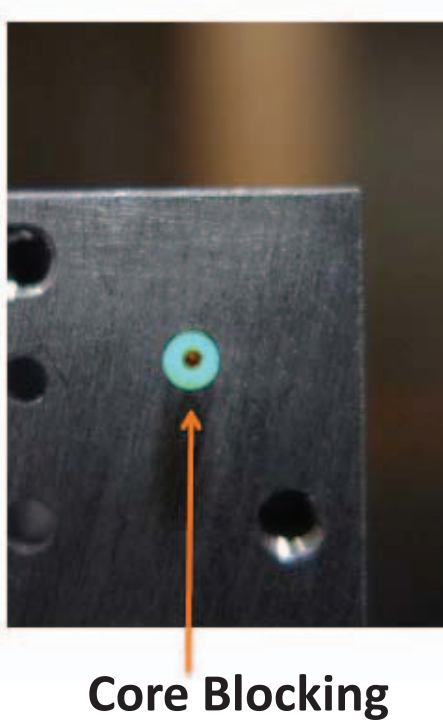

Fig. 10. Example of an excited fiber with core blocking.

VII. CAPILLARY EVALUATION AND TESTING

The capillary is tested for linear response along the length of the capillary and for response at different levels of radiation damage.

Figure 11 shows the data of an example capillary tested with core blocking only, and with core blocking and diffuse

reflector (TiO₂). Note that the diffuse reflector raises the light level overall, and makes the capillary more linear as the far end light collection is improved.

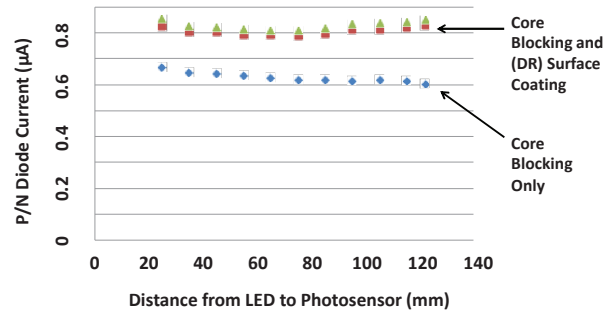

Fig. 11. Data from a capillary with core blocking only and core blocking and diffuse reflector.

Each capillary is tested in this fashion before it is placed into the Shashlik test system or goes on for further testing for radiation damage effects.

To test for the effects of high doses of gamma rays, capillaries have been exposed to ⁶⁰Co gamma irradiation at the Notre Dame Radiation Laboratory where they are exposed at the rate of ~1 Mrad every 45 minutes. In a weekend it is possible expose a sample to a 50 Mrad dose.

The samples are tested between doses in the direct LED system. Fig. 12 shows results of one such capillary from 50-200 Mad. Note that 0 Mrad is not shown but would be nominally 1 on the scale.

Of particular interest is the fact that after larger doses of gammas, while the light levels drop, the response remains relatively flat along the length of the capillary. This is very important for use in EM calorimeters as the energy measurement requires a flat response.

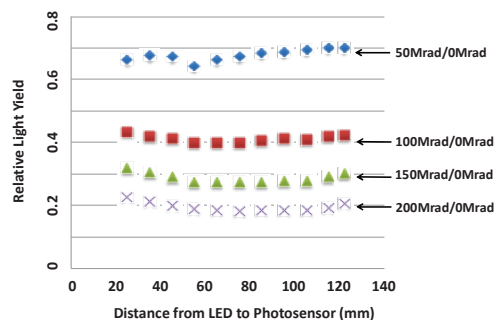

Fig. 12. Effects of radiation on the capillaries.

VIII. FUTURE WORK UNDERWAY AND PLANNED

Future work will center on capillary fabrication (at ND), and commercial manufacture of the capillaries to make the capillaries more uniform.

We will also focus on wavelength shifting dyes including but not limited to DSB1, J2, DSB2, DSF1, Quantum Dots and further work will go into more detail on the dye concentrations.

We will also focus on possibly different core blocking materials to improve that area of the capillary manufacture.

Testing at CERN in the test beam is also underway to evaluate the 4 X 4 test system with capillaries.

IX. SUMMARY

Shashlik technology can provide robust, efficient and high resolution EM Calorimetry under harsh conditions in Particle Physics Experiments. The results of the development so far have yielded sealed robust capillaries that can be used in such a detector that exhibit characteristic needed to make such a device work

ACKNOWLEDGMENT

Special thanks to the Radiation Laboratory at Notre Dame for making the capillaries for us and to Kiva Ford who does the glass work. And thanks to Jay LaVerne of the Notre Dame Radiation Lab for his help in exposing our sample to high doses of gamma radiation.

Thanks to Eljen Technologies and especially Chuck Hurbut for making the liquids at various concentration we needed to complete this work.

And special thanks to the people at Polymicro Technologies for making the blank radiation hard quartz capillaries to our specification.

We thank the National Science Foundation for its support of this work under grant NSF-PHY-1312842.